

## 74F323 Octal Universal Shift/Storage Register with Synchronous Reset and Common I/O Pins

### General Description

The 74F323 is an 8-bit universal shift/storage register with 3-STATE outputs. Its function is similar to the 74F299 with the exception of Synchronous Reset. Parallel load inputs and flip-flop outputs are multiplexed to minimize pin count. Separate serial inputs and outputs are provided for  $Q_0$  and  $Q_7$  to allow easy cascading. Four operation modes are possible: hold (store), shift left, shift right and parallel load.

### Features

- Common parallel I/O for reduced pin count
- Additional serial inputs and outputs for expansion
- Four operating modes: shift left, shift right, load and store
- 3-STATE outputs for bus-oriented applications

### Ordering Code:

Order Number	Package Number	Package Description
74F323SC	M20B	20-Lead Small Outline Integrated Circuit (SOIC), JEDEC MS-013, 0.300 Wide
74F323PC	N20A	20-Lead Plastic Dual-In-Line Package (PDIP), JEDEC MS-001, 0.300 Wide

Devices also available in Tape and Reel. Specify by appending the suffix letter "X" to the ordering code.

### Logic Symbols

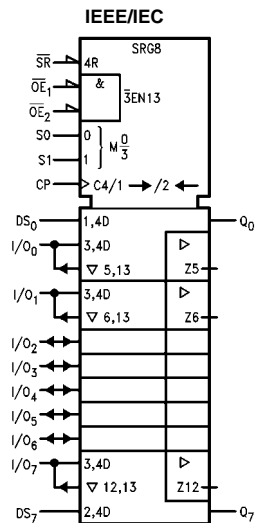
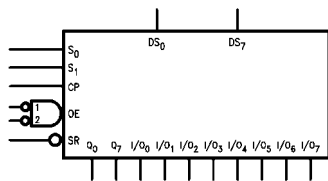

### Connection Diagram

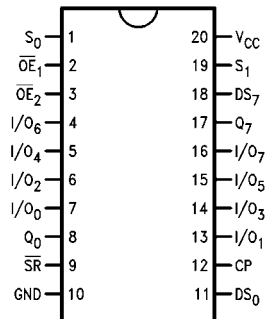

## Unit Loading/Fan Out

Pin Names	Description	U.L.	
		HIGH/LOW	Input $I_{IH}/I_{IL}$ Output $I_{OH}/I_{OL}$
CP	Clock Pulse Input (Active Rising Edge)	1.0/1.0	20 $\mu$ A/-0.6 mA
DS <sub>0</sub>	Serial Data Input for Right Shift	1.0/1.0	20 $\mu$ A/-0.6 mA
DS <sub>7</sub>	Serial Data Input for Left Shift	1.0/1.0	20 $\mu$ A/-0.6 mA
S <sub>0</sub> , S <sub>1</sub>	Mode Select Inputs	1.0/2.0	20 $\mu$ A/-1.2 mA
$\overline{SR}$	Synchronous Reset Input (Active LOW)	1.0/1.0	20 $\mu$ A/-0.6 mA
$\overline{OE}_1, \overline{OE}_2$	3-STATE Output Enable Inputs (Active LOW)	1.0/1.0	20 $\mu$ A/-0.6 mA
I/O <sub>0</sub> -I/O <sub>7</sub>	Multiplexed Parallel Data Inputs 3-STATE Parallel Data Outputs	3.5/1.083 150/40 (33.3)	70 $\mu$ A/-0.65 mA -3 mA/24 mA (20 mA)
Q <sub>0</sub> , Q <sub>7</sub>	Serial Outputs	50/33.3	-1 mA/20 mA

## Functional Description

The 74F323 contains eight edge-triggered D-type flip-flops and the interstage logic necessary to perform synchronous reset, shift left, shift right, parallel load and hold operations. The type of operation is determined by S<sub>0</sub> and S<sub>1</sub> as shown in the Mode Select Table. All flip-flop outputs are brought out through 3-STATE buffers to separate I/O pins that also serve as data inputs in the parallel load mode. Q<sub>0</sub> and Q<sub>7</sub> are also brought out on other pins for expansion in serial shifting of longer words.

A LOW signal on  $\overline{SR}$  overrides the Select inputs and allows the flip-flops to be reset by the next rising edge of CP. All other state changes are also initiated by the LOW-to-HIGH CP transition. Inputs can change when the clock is in either state provided only that the recommended setup and hold times, relative to the rising edge of CP, are observed.

A HIGH signal on either  $\overline{OE}_1$  or  $\overline{OE}_2$  disables the 3-STATE buffers and puts the I/O pins in the high impedance state. In this condition the shift, load, hold and reset operations can still occur. The 3-STATE buffers are also disabled by HIGH signals on both S<sub>0</sub> and S<sub>1</sub> in preparation for a parallel load operation.

## Mode Select Table

Inputs				Response
SR	S <sub>1</sub>	S <sub>0</sub>	CP	
L	X	X	$\nearrow$	Synchronous Reset; Q <sub>0</sub> -Q <sub>7</sub> = LOW
H	H	H	$\nearrow$	Parallel Load; I/O <sub>n</sub> → Q <sub>n</sub>
H	L	H	$\nearrow$	Shift Right; DS <sub>0</sub> → Q <sub>0</sub> , Q <sub>0</sub> → Q <sub>1</sub> , etc.
H	H	L	$\nearrow$	Shift Left; DS <sub>7</sub> → Q <sub>7</sub> , Q <sub>7</sub> → Q <sub>6</sub> , etc.
H	L	L	X	Hold

H = HIGH Voltage Level  
L = LOW Voltage Level  
X = Immaterial  
 $\nearrow$  = LOW-to-HIGH transition

## Logic Diagram

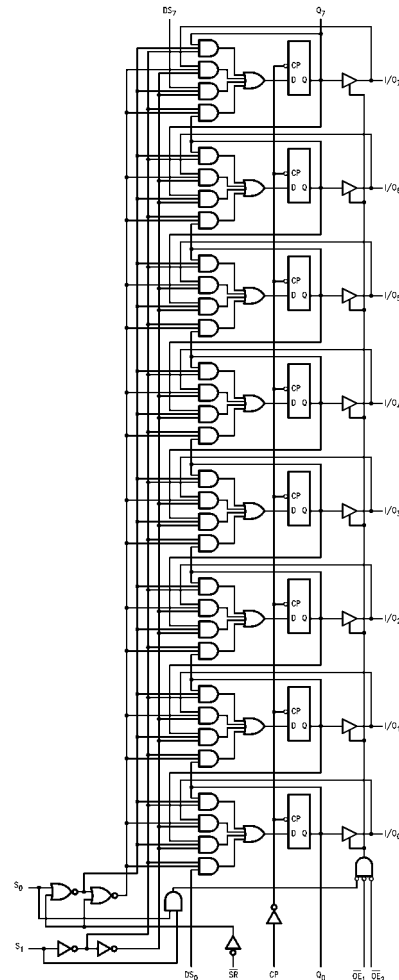

Please note that this diagram is provided only for the understanding of logic operations and should not be used to estimate propagation delays.

**Absolute Maximum Ratings**(Note 1)

Storage Temperature	-65°C to +150°C
Ambient Temperature under Bias	-55°C to +125°C
Junction Temperature under Bias	-55°C to +150°C
V <sub>CC</sub> Pin Potential to Ground Pin	-0.5V to +7.0V
Input Voltage (Note 2)	-0.5V to +7.0V
Input Current (Note 2)	-30 mA to +5.0 mA
Voltage Applied to Output in HIGH State (with V <sub>CC</sub> = 0V)	
Standard Output	-0.5V to V <sub>CC</sub>
3-STATE Output	-0.5V to +5.5V
Current Applied to Output in LOW State (Max)	twice the rated I <sub>OL</sub> (mA)
ESD Last Passing Voltage (Min)	4000V

**Recommended Operating Conditions**

Free Air Ambient Temperature	0°C to +70°C
Supply Voltage	+4.5V to +5.5V

**Note 1:** Absolute maximum ratings are values beyond which the device may be damaged or have its useful life impaired. Functional operation under these conditions is not implied.

**Note 2:** Either voltage limit or current limit is sufficient to protect inputs.

**DC Electrical Characteristics**

Symbol	Parameter	Min	Typ	Max	Units	V <sub>CC</sub>	Conditions	
V <sub>IH</sub>	Input HIGH Voltage	2.0			V		Recognized as a HIGH Signal	
V <sub>IL</sub>	Input LOW Voltage			0.8	V		Recognized as a LOW Signal	
V <sub>CD</sub>	Input Clamp Diode Voltage			-1.2	V	Min	I <sub>IN</sub> = -18 mA	
V <sub>OH</sub>	Output HIGH Voltage	10% V <sub>CC</sub>	2.5			V	Min	I <sub>OH</sub> = -1 mA (Q <sub>0</sub> , Q <sub>7</sub> )
		10% V <sub>CC</sub>	2.4		I <sub>OH</sub> = -3 mA (I/O <sub>n</sub> )			
		5% V <sub>CC</sub>	2.7		I <sub>OH</sub> = -1 mA (Q <sub>0</sub> , Q <sub>7</sub> )			
		5% V <sub>CC</sub>	2.7		I <sub>OH</sub> = -3 mA (I/O <sub>n</sub> )			
V <sub>OL</sub>	Output LOW Voltage	10% V <sub>CC</sub>		0.5	V	Min	I <sub>OL</sub> = 20 mA (Q <sub>0</sub> , Q <sub>7</sub> )	
		10% V <sub>CC</sub>		0.5			I <sub>OL</sub> = 24 mA (I/O <sub>n</sub> )	
I <sub>IH</sub>	Input HIGH Current			5.0	μA	Max	V <sub>IN</sub> = 2.7V	
I <sub>BVI</sub>	Input HIGH Current Breakdown Test			7.0	μA	Max	V <sub>IN</sub> = 7.0V (Non I/O Inputs)	
I <sub>BVIT</sub>	Input HIGH Current Breakdown (I/O)			0.5	mA	Max	V <sub>IN</sub> = 5.5V (I/O Inputs)	
I <sub>CEX</sub>	Output HIGH Leakage Current			50	μA	Max	V <sub>OUT</sub> = V <sub>CC</sub>	
V <sub>ID</sub>	Input Leakage Test	4.75			V	0.0	I <sub>ID</sub> = 1.9 μA All Other Pins Grounded	
I <sub>OD</sub>	Output Leakage Circuit Current			3.75	μA	0.0	V <sub>IOD</sub> = 150 mV All Other Pins Grounded	
I <sub>IL</sub>	Input LOW Current			-0.6	mA	Max	V <sub>IN</sub> = 0.5V (CP, DS <sub>0</sub> , DS <sub>7</sub> , $\overline{\text{SR}}$ , $\overline{\text{OE}}_1$ , $\overline{\text{OE}}_2$ )	
				-1.2	mA	Max	V <sub>IN</sub> = 0.5V (S <sub>0</sub> , S <sub>1</sub> )	
I <sub>OS</sub>	Output Short-Circuit Current	-60		-150	mA	Max	V <sub>OUT</sub> = 0V	
I <sub>ZZ</sub>	Bus Drainage Test			500	μA	0.0V	V <sub>OUT</sub> = 5.25V	
I <sub>CCH</sub>	Power Supply Current		68	95	mA	Max	V <sub>O</sub> = HIGH	
I <sub>CCL</sub>	Power Supply Current		68	95	mA	Max	V <sub>O</sub> = LOW	
I <sub>CCZ</sub>	Power Supply Current		68	95	mA	Max	V <sub>O</sub> = HIGH Z	

AC Electrical Characteristics							
Symbol	Parameter	T <sub>A</sub> = +25°C V <sub>CC</sub> = +5.0V C <sub>L</sub> = 50 pF			T <sub>A</sub> = 0°C to +70°C V <sub>CC</sub> = +5.0V C <sub>L</sub> = 50 pF		Units
		Min	Typ	Max	Min	Max	
t <sub>MAX</sub>	Maximum Input Frequency	70	100		70		MHz
t <sub>PLH</sub>	Propagation Delay	4.0	7.0	8.0	4.0	8.5	ns
t <sub>PHL</sub>	CP to Q <sub>0</sub> or Q <sub>7</sub>	4.5	6.5	8.0	4.5	8.5	
t <sub>PLH</sub>	Propagation Delay	3.5	7.0	9.0	3.5	10.0	
t <sub>PHL</sub>	CP to I/O <sub>n</sub>	4.0	8.5	9.0	4.0	10.0	
t <sub>PZH</sub>	Output Enable Time	3.5	6.0	8.0	3.5	9.0	ns
t <sub>PZL</sub>		4.0	7.0	10.0	4.0	11.0	
t <sub>PHZ</sub>	Output Disable Time	2.0	4.5	6.0	2.0	7.0	
t <sub>PLZ</sub>		1.0	4.0	5.5	1.0	6.5	ns
t <sub>PZH</sub>	Output Enable Time	3.5		9.0	3.5	10.0	
t <sub>PZL</sub>	S <sub>n</sub> to I/O <sub>n</sub>	4.0		10.0	4.0	11.0	ns
t <sub>PHZ</sub>	Output Disable Time	2.5		6.0	2.5	7.0	ns
t <sub>PLZ</sub>	S <sub>n</sub> to I/O <sub>n</sub>	1.0		5.5	1.5	6.5	
AC Operating Requirements							
Symbol	Parameter	T <sub>A</sub> = +25°C V <sub>CC</sub> = +5.0V		T <sub>A</sub> = 0°C to +70°C V <sub>CC</sub> = +5.0V		Units	
		Min	Max	Min	Max		
t <sub>S</sub> (H)	Setup Time, HIGH or LOW	8.5		8.5		ns	
t <sub>S</sub> (L)	S <sub>0</sub> or S <sub>1</sub> to CP	8.5		8.5			
t <sub>H</sub> (H)	Hold Time, HIGH or LOW	0		0			
t <sub>H</sub> (L)	S <sub>0</sub> or S <sub>1</sub> to CP	0		0			
t <sub>S</sub> (H)	Setup Time, HIGH or LOW	5.0		5.0		ns	
t <sub>S</sub> (L)	I/O <sub>n</sub> , DS <sub>0</sub> , DS <sub>7</sub> to CP	5.0		5.0			
t <sub>H</sub> (H)	Hold Time, HIGH or LOW	2.0		2.0			
t <sub>H</sub> (L)	I/O <sub>n</sub> , DS <sub>0</sub> , DS <sub>7</sub> to CP	2.0		2.0			
t <sub>S</sub> (H)	Setup Time, HIGH or LOW	10.0		10.0		ns	
t <sub>S</sub> (L)	SR to CP	10.0		10.0			
t <sub>H</sub> (H)	Hold Time, HIGH or LOW	0		0			
t <sub>H</sub> (L)	SR to CP	0		0			
t <sub>W</sub> (H)	CP Pulse Width	5.0		5.0		ns	
t <sub>W</sub> (L)	HIGH or LOW	5.0		5.0			

**Physical Dimensions** inches (millimeters) unless otherwise noted

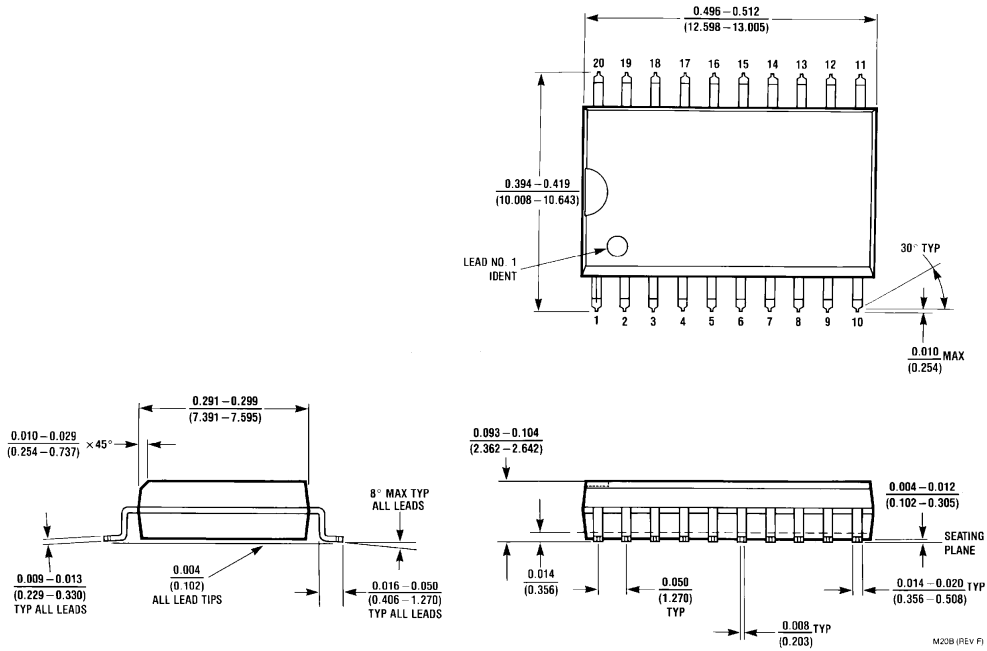

**20-Lead Small Outline Integrated Circuit (SOIC), JEDEC MS-013, 0.300 Wide  
Package Number M20B**

M20B (REV F)

**Physical Dimensions** inches (millimeters) unless otherwise noted (Continued)

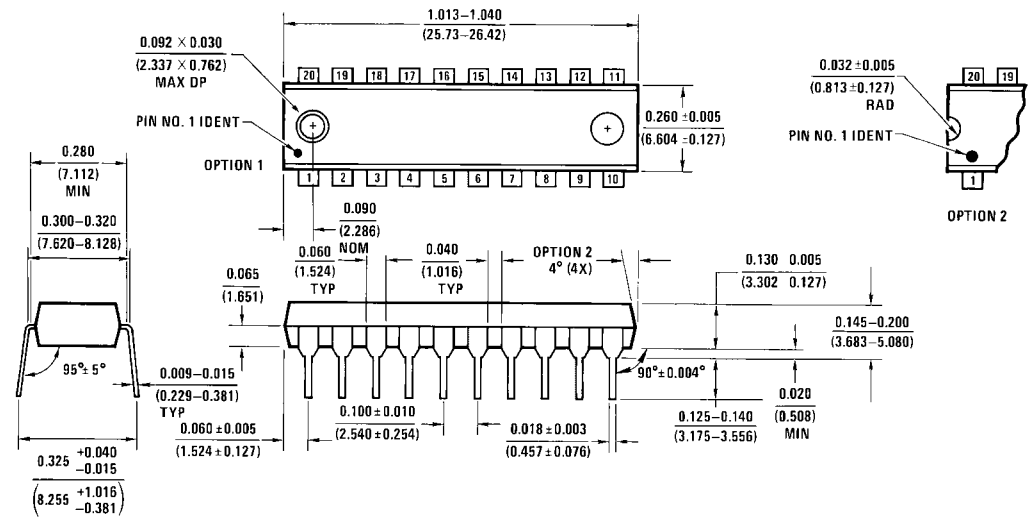

20-Lead Plastic Dual-In-Line Package (PDIP), JEDEC MS-001, 0.300 Wide Package Number N20A

N20A (REV G)

Fairchild does not assume any responsibility for use of any circuitry described, no circuit patent licenses are implied and Fairchild reserves the right at any time without notice to change said circuitry and specifications.

**LIFE SUPPORT POLICY**

FAIRCHILD'S PRODUCTS ARE NOT AUTHORIZED FOR USE AS CRITICAL COMPONENTS IN LIFE SUPPORT DEVICES OR SYSTEMS WITHOUT THE EXPRESS WRITTEN APPROVAL OF THE PRESIDENT OF FAIRCHILD SEMICONDUCTOR CORPORATION. As used herein:

1. Life support devices or systems are devices or systems which, (a) are intended for surgical implant into the body, or (b) support or sustain life, and (c) whose failure to perform when properly used in accordance with instructions for use provided in the labeling, can be reasonably expected to result in a significant injury to the user.
2. A critical component in any component of a life support device or system whose failure to perform can be reasonably expected to cause the failure of the life support device or system, or to affect its safety or effectiveness.

[www.fairchildsemi.com](http://www.fairchildsemi.com)